

<http://www.Drshokuhi.com>

سایت آموزش مهندسی مکانیک ایران

Remarks on plastic material behavior

1) Yield surfaces (a surface in the stress space representing the condition/criterion whether the solid responds elastically or plastically to the applied load)

The von Mises and Tresca yield conditions are represented by the following yield surfaces in the stress space (view long the $\frac{1}{\sqrt{3}}(1, 1, 1)$ direction).

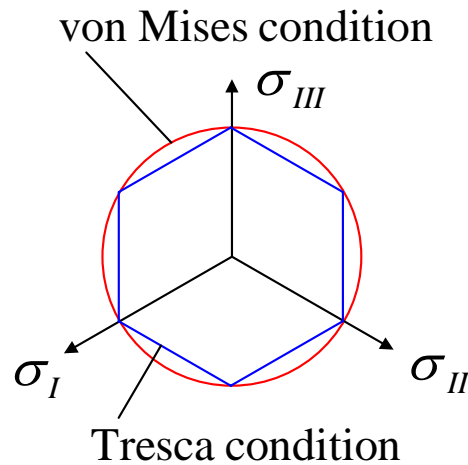

2) The strain can be decomposed into elastic and plastic parts. In incremental form,

$$d\underline{\varepsilon} = d\underline{\varepsilon}^E + d\underline{\varepsilon}^P$$

The elastic part is related to stress via the usual linear elastic equations. The plastic part of strain in incremental form can be written as

$$d\varepsilon_{ij}^P = \begin{cases} \frac{3}{2} \sigma'_{ij} \frac{d\varepsilon_p}{\sigma_e}, & \text{if } \sigma_e = \sigma_Y, d\sigma_e \geq 0 \\ 0, & \text{otherwise} \end{cases}$$

J_2 - flow theory:

$$J_2 = \frac{1}{2} \sigma'_{ij} \sigma'_{ij}, \quad \frac{\partial J_2}{\partial \sigma'_{ij}} = \sigma'_{ij}$$

Based on the above relations, the plastic strain can be rewritten in term of J_2 as

$$d\varepsilon_{ij}^P = \begin{cases} \frac{3}{2} \frac{\partial J_2}{\partial \sigma'_{ij}} \frac{d\varepsilon_P}{\sigma_e}, & \text{loading} \\ 0, & \text{otherwise} \end{cases}$$

3) Normality rule

Yield stress:

$$\sigma_e = \sqrt{\frac{3}{2} \sigma'_{ij} \sigma'_{ij}} = \sigma_Y \quad \Rightarrow \quad f(\sigma'_{ij}) = \sigma_Y$$

where $f(\sigma'_{ij})$ represents a general yield surface.

Differentiate the equation $\frac{3}{2} \sigma'_{ij} \sigma'_{ij} = \sigma_e^2$ gives

$$d\left(\frac{3}{2} \sigma'_{ij} \sigma'_{ij}\right) = d(\sigma_e^2) \quad \Rightarrow \quad \frac{3}{2} \sigma'_{ij} d\sigma'_{ij} = \sigma_e d\sigma_e \quad \Rightarrow \quad \frac{\partial \sigma_e}{\partial \sigma'_{ij}} = \frac{3}{2} \frac{\sigma'_{ij}}{\sigma_e}$$

The plastic strain for a general yield condition $f(\sigma'_{ij})$ can be written as

$$d\varepsilon_{ij}^P = \begin{cases} \frac{\partial f}{\partial \sigma'_{ij}} d\varepsilon_P, & \text{if } f = \sigma_Y, d\varepsilon_P \geq 0 \\ 0, & \text{otherwise} \end{cases}$$

which also indicates $d\underline{\varepsilon}^P$ is normal to the yield surfaces.

4) Convexity rule

The yield surface must be convex for plastically stable solids. One cannot have a nonconvex yield surface such as the figure below.

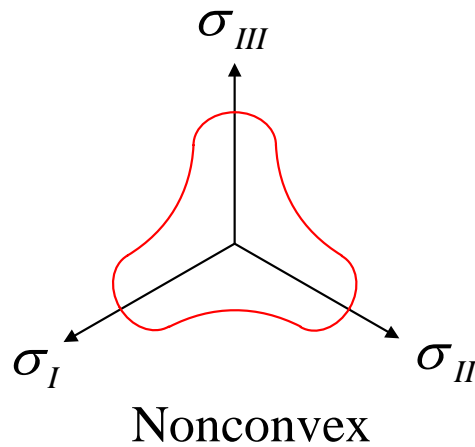

The convexity rule can be related to principle of maximum plastic resistance.

5) Limitations of von Mises law $\sigma_e = \sigma_Y$

Cyclic loading:

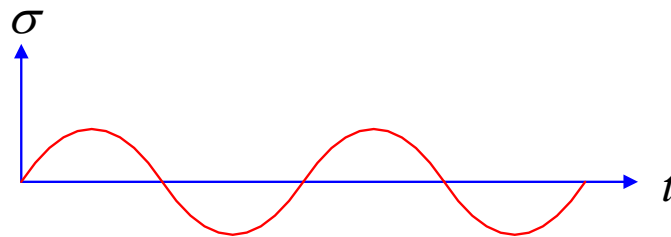

The $\sigma = \varepsilon$ curve under a cyclic loading is illustrated below.

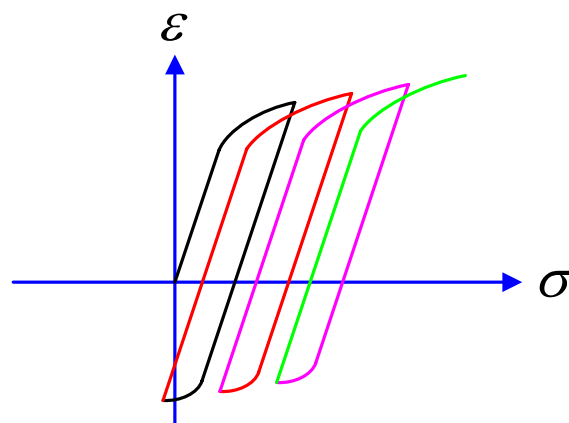

The isotropic hardening as implied by von Mises condition ($\sqrt{\frac{3}{2} \sigma'_{ij} \sigma'_{ij}} = \sigma_Y$) is generally not

valid in case of cyclic loading. The so-called Bauschinger effect indicates that, if the solid first undergoes plastic deformation in tension and then loaded in compression, the yield stress in

compression would generally become smaller. Alternatively, deforming the material in compression also tends to soften the material in tension. To account for this, kinematic hardening laws have been proposed to allow the yield surface to translate, without changing its shape, in stress space.

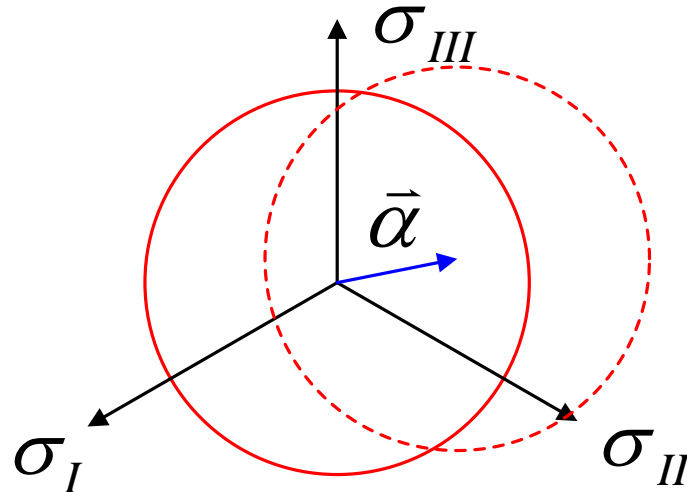

To account for the fact that yield surface translate without changing its shape in cyclic loading, the von Mises yield condition can be modified as

$$f(\sigma'_{ij}) = \sqrt{\frac{3}{2}(\sigma'_{ij} - \alpha_{ij})(\sigma'_{ij} - \alpha_{ij})} = \sigma_Y$$

6) J_2 - deformation theory

If there is no unloading and the stresses increase proportionally to each other. The J_2 - flow theory can be integrated to give the so-called J_2 - deformation theory of plasticity.

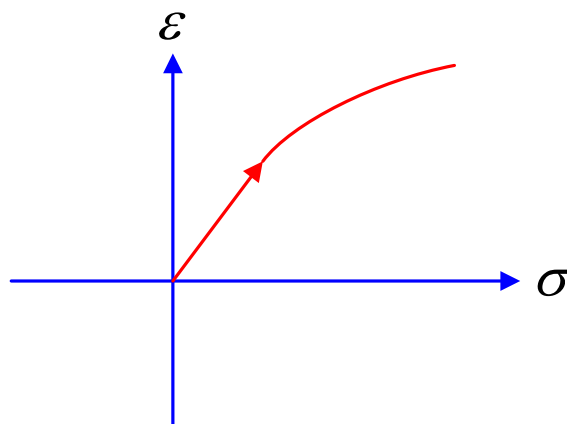

$$d\sigma'_{ij} = \sigma'_{ij,0} d\epsilon \Rightarrow \epsilon_{ij}^P = \frac{\partial f}{\partial \sigma'_{ij}} \epsilon_P$$

$$\varepsilon_{ij}^E = \frac{1+\nu}{E} \sigma_{ij} - \frac{\nu}{E} \sigma_{kk}$$

7) Single crystal plasticity (1970s-)

Modeling plastic deformation by considering slip along discrete crystal planes and orientations.

e.g. Cu: FCC crystal, 12 slip systems: 4 {111} planes time 3 [110] directions.

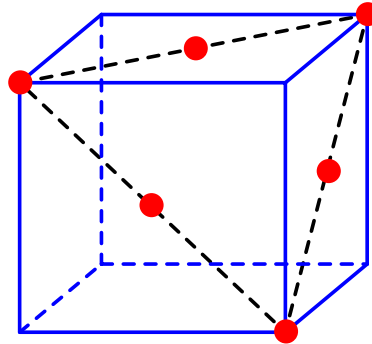

Viscoelasticity

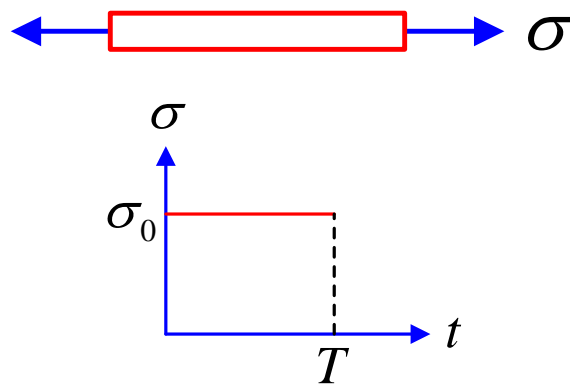

For a constant loading σ_0 acting from time 0 to T , the strain responses of elastic materials and viscoelastic materials are illustrated in the figures below.

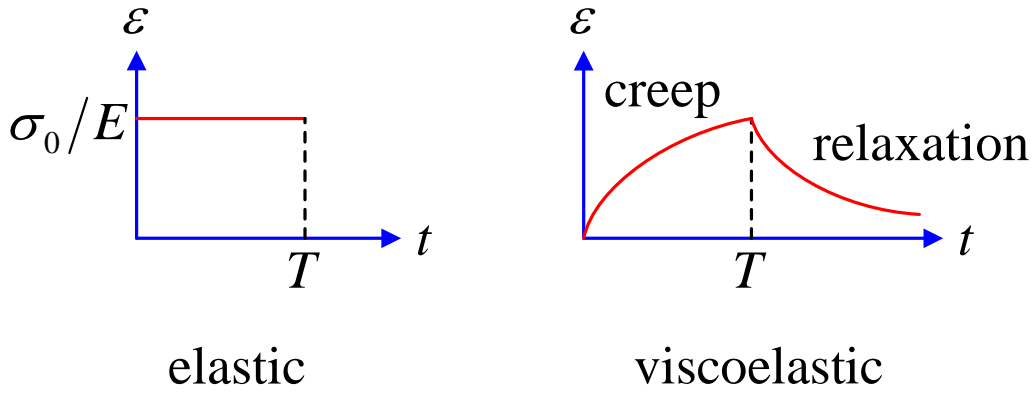

Mathematical tools

Spring: $\sigma = E\varepsilon \Rightarrow \varepsilon = \frac{\sigma}{E}$



Dash pot: $\sigma = \eta\dot{\varepsilon} \Rightarrow \dot{\varepsilon} = \frac{\sigma}{\eta}$

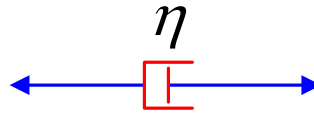

Basic viscoelastic models:

Maxwell model:

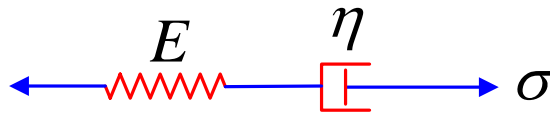

$$\dot{\varepsilon} = \dot{\varepsilon}_E + \dot{\varepsilon}_\eta = \frac{\dot{\sigma}}{E} + \frac{\sigma}{\eta}$$

The strain response of Maxwell model to a constant loading σ_0 acting from time 0 to T is

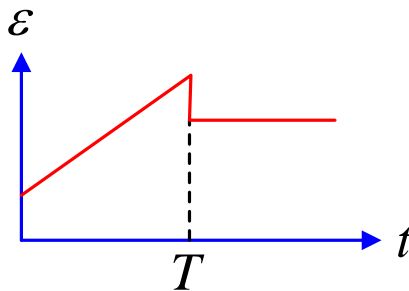

Kevin model:

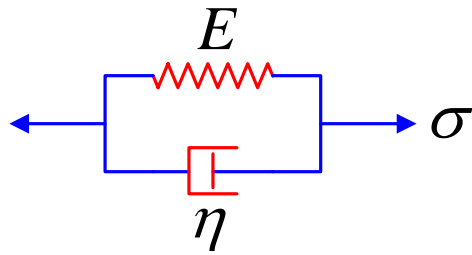

$$\sigma = \sigma_E + \sigma_\eta = E\varepsilon + \eta\dot{\varepsilon}$$

The strain response of Kelvin model to a constant loading σ_0 acting from time 0 to T is

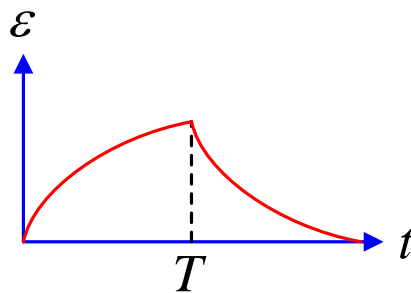

Standard linear solid model:

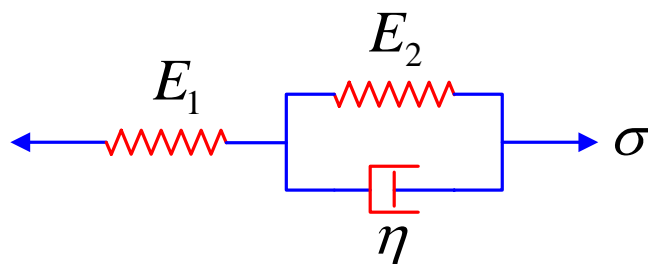

The strain response of standard linear solid model to a constant loading σ_0 acting from time 0 to T is

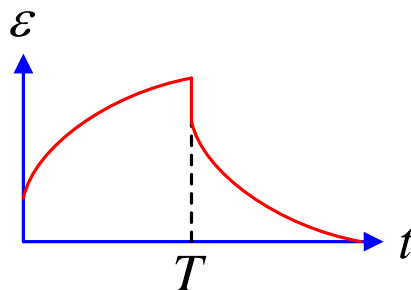

More sophisticated models (e.g., for biological systems)

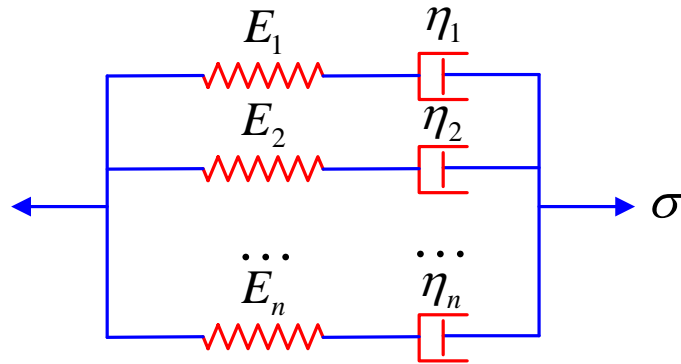
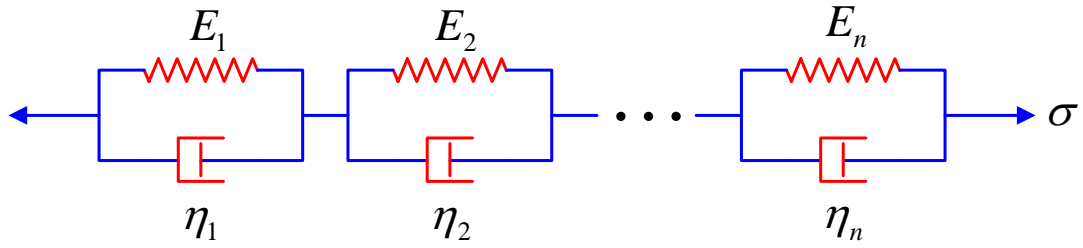

General mathematical structure of viscoelastic models:

$$\left(p_0 + p_1 \frac{\partial}{\partial t} + p_2 \frac{\partial^2}{\partial t^2} + \dots + p_n \frac{\partial^n}{\partial t^n} \right) \sigma = \left(q_0 + q_1 \frac{\partial}{\partial t} + q_2 \frac{\partial^2}{\partial t^2} + \dots + q_n \frac{\partial^n}{\partial t^n} \right) (E \varepsilon)$$

$$P \sigma = Q(E \varepsilon)$$

Sometimes fractional derivatives (like $\frac{\partial^{1/2}}{\partial t^{1/2}}$) have also been used to describe the stress-strain relations of complex viscoelastic responses.

Generalize to 3D,

Linear elastic: $\sigma = E \varepsilon$ is generalized to $\sigma'_{ij} = 2\mu \varepsilon'_{ij}$, $\sigma_{kk} = 3K \varepsilon_{kk}$

Viscoelastic: $P \sigma = Q(E \varepsilon)$ can be likewise generalized to $P \sigma'_{ij} = Q(2\mu \varepsilon'_{ij})$,

$$P \sigma_{kk} = Q(3K \varepsilon_{kk})$$

Additional remarks on viscoelasticity:



1) Creep modulus: the strain response to a unit constant stress.

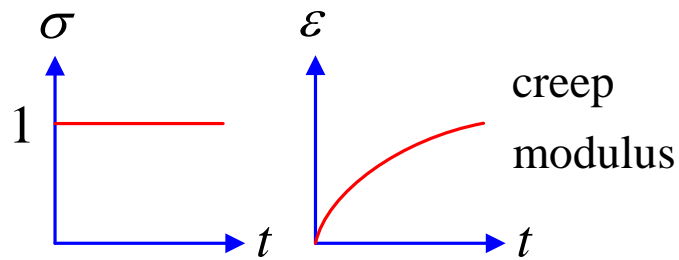

Relaxation modulus: the stress response to a unit constant strain.

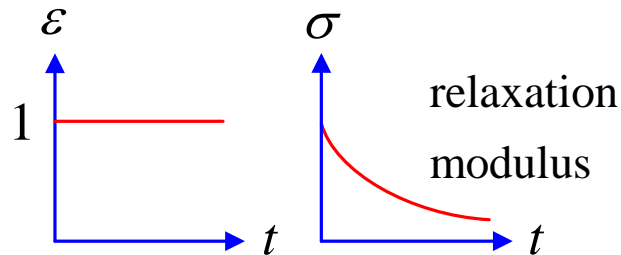

2) Storage & loss modulus

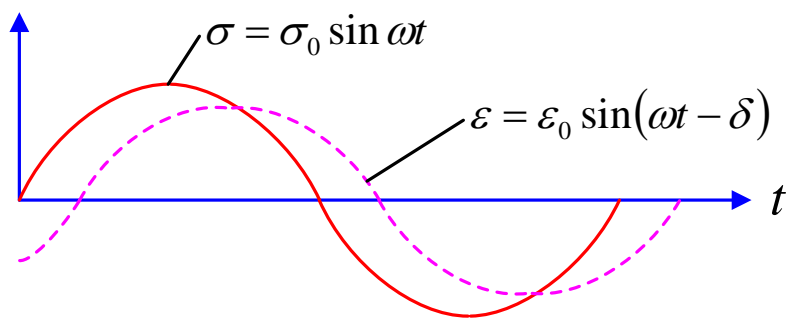

Elastic case: $\sigma = \sigma_0 \sin \omega t$, $\varepsilon = \frac{\sigma_0}{E} \sin \omega t = \varepsilon_0 \sin \omega t$ (no delay for strain response)

Viscoelastic case: $\varepsilon = \varepsilon_0 \sin(\omega t - \delta) = \varepsilon_0 \cos \delta \sin \omega t - \varepsilon_0 \sin \delta \cos \omega t$

$\frac{\varepsilon_0 \cos \delta}{\sigma_0}$: storage compliance

$\frac{\varepsilon_0 \sin \delta}{\sigma_0}$: loss compliance